

# 1310/1550 nm High Power Optical Circulator

DATASHEET

BUY NOW



The 1310/1550 nm high power optical circulator is designed for high power applications. This non-reciprocal device redirects light at 1310/1550 nm wavelengths from port-to-port in only one direction while minimizing back reflection and back scattering in the reverse directions for any state of polarization. Employing Agiltron's advanced micro optics design, it features low insertion loss, low polarization sensitivity, high isolation, compact structure and high stability. The excellent characteristics of this product make it an ideal choice for application in fiber amplifier systems, pump laser diodes and optical fiber sensors. This circulator can be made using a variety of fibers including HI980, HI1060, LMA and double cladding fibers.

## Applications

- Optical Fiber Amplifier
- Metropolitan Area Network
- Fiber Optic Sensor
- Dispersion Compensation
- Test and Measurement
- Instrumentation

## Features

- High Power Handling
- Low Insertion Loss
- Low PDL
- High Channel Isolation
- Compact Package
- High Reliability & Stability
- Cost Effective

## Specifications

Parameter	Min	Typical	Max	Unit	
Operating Wavelength	1310	1295	1325	nm	
	C Band	1530	1570		
	L Band	1570	1610		
	C + L	1525	1610		
Insertion Loss <sup>[1]</sup>	3-Port	1310	0.6	0.9	dB
		C, L	0.6	0.9	dB
	4-Port	C + L	0.7	1.0	dB
		1310, C, L	0.7	1.0	dB
Isolation (2→1, 3→2, or 4→3) <sup>[2]</sup>	3-Port	1310	36		dB
		C, L	36		dB
	4-Port	C + L	30		dB
		1310, C, L	36		dB
Directivity (1→3 or 2→4)		> 50		dB	
Polarization Dependent Loss	3-Port	< 0.10		dB	
	4-Port	< 0.15		dB	
Polarization Mode Dispersion		< 0.1		ps	
Return Loss		> 50		dB	
Optical Power Handling		< 5 <sup>[3]</sup>		W	
Operating Temperature Range	0		70	°C	
Storage Temperature	-40		85	°C	
Fiber Type	Corning SMF-28				
Fiber Length		> 1		m	

### Notes:

- [1] Excluding connectors
- [2] @ $\lambda_{op}$ , Top, SOP
- [3] Continuous operation, for pulse operation call

**Note:** For a polarized input light version, the isolation is optimized to block the light reflection of the same polarization. Although lights of other polarizations may also be blocked, the extinction may be poor. PM isolators can be specially made to block backward propagating lights of all polarizations. PM isolators can also be made with a light polarizing function.

**Legal notices:** All product information is believed to be accurate and is subject to change without notice. Information contained herein shall legally bind Agiltron only if it is specifically incorporated into the terms and conditions of a sales agreement. Some specific combinations of options may not be available. The user assumes all risks and liability whatsoever in connection with the use of a product or its application.

Rev 08/14/24

# 1310/1550 nm High Power Optical Circulator

## DATASHEET

### Mechanical Dimensions (mm)

#### 3-Port Circulator

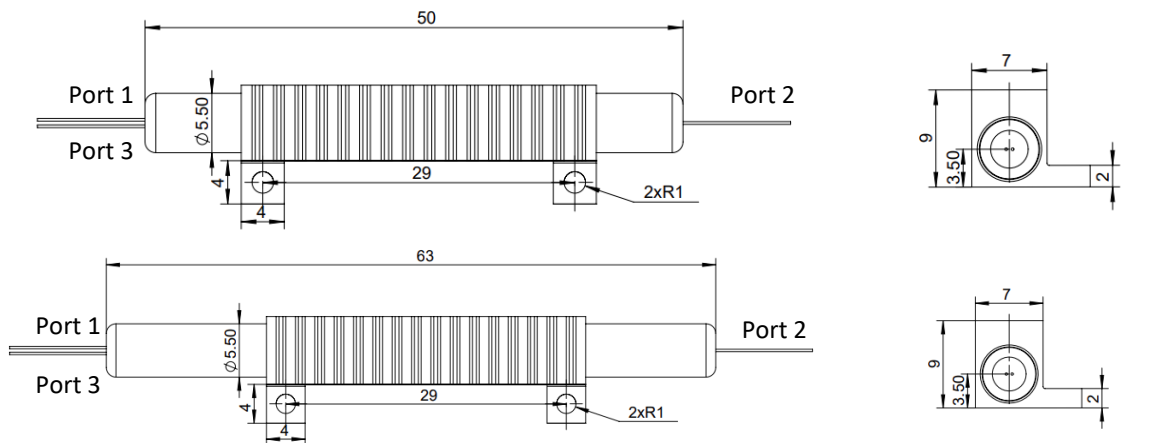

#### 4-Port Circulator

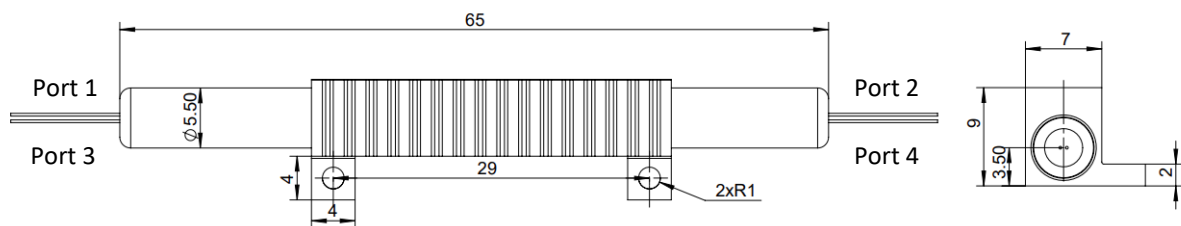

\*Product dimensions may change without notice. This is sometimes required for non-standard specifications.

# 1310/1550 nm High Power Optical Circulator

## DATASHEET

### Ordering Information

Prefix	Type	Wavelength	Grade	Package	Fiber Type	Fiber Cover	Fiber Length	Connector
OCHP-	3 Port = 30 4 Port = 40 Special = 00	1310 = 3 1550 = 5 C-band = C L-band = L C+L = 2 Special = 0	Standard = 1 Special = 2	5.5 x 50 = 1 5.5 x 63 = 2 5.5 x 65 = 3 Special = 0	SMF-28 = 1 PM1550 = B Special = 0	Bare fiber = 1 900um loose tube = 3 250um = 4 Special = 0	0.25m = 1 0.5 m = 2 1.0 m = 3 Special = 0	None = 1 FC/PC = 2 FC/APC = 3 SC/PC = 4 SC/APC = 5 ST/PC = 6 LC/PC = 7 LC/APC = A LC/UPC = U Special = 0

\* Agiltron provide high power connector, please call.

#### Fiber Core Alignment

Note that the minimum attenuation for these devices depends on excellent core-to-core alignment when the connectors are mated. This is crucial for shorter wavelengths with smaller fiber core diameters that can increase the loss of many decibels above the specification if they are not perfectly aligned. Different vendors' connectors may not mate well with each other, especially for angled APC.

#### Fiber Cleanliness

Fibers with smaller core diameters (<5 μm) must be kept extremely clean, contamination at fiber-fiber interfaces, combined with the high optical power density, can lead to significant optical damage. This type of damage usually requires re-polishing or replacement of the connector.

#### Maximum Optical Input Power

Due to their small fiber core diameters for short wavelength and high photon energies, the damage thresholds for device is substantially reduced than the common 1550nm fiber. To avoid damage to the exposed fiber end faces and internal components, the optical input power should never exceed 20 mW for wavelengths shorter 650nm. We produce a special version to increase the how handling by expanding the core side at the fiber ends.

# 1310/1550 nm High Power Optical Circulator

## DATASHEET

### Typical Wavelength Dependence for Single Stage

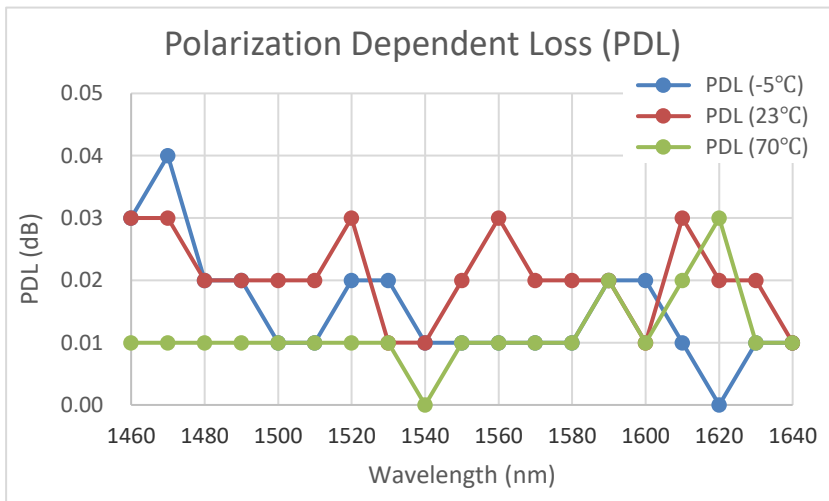
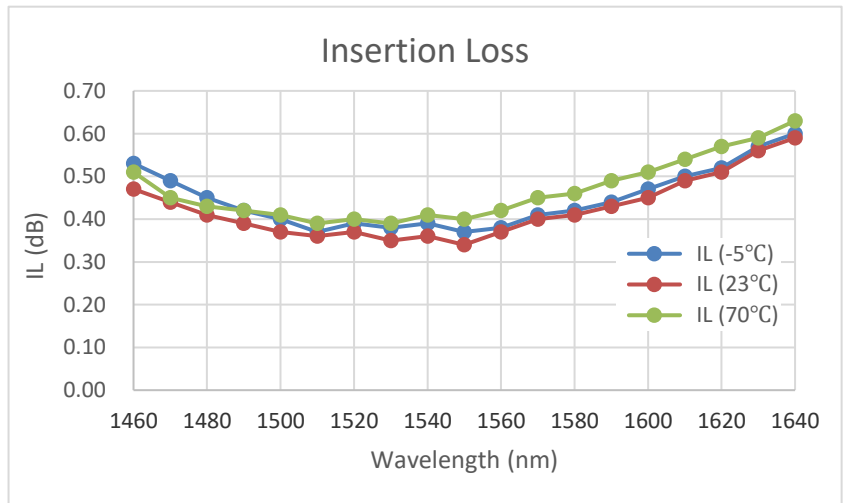
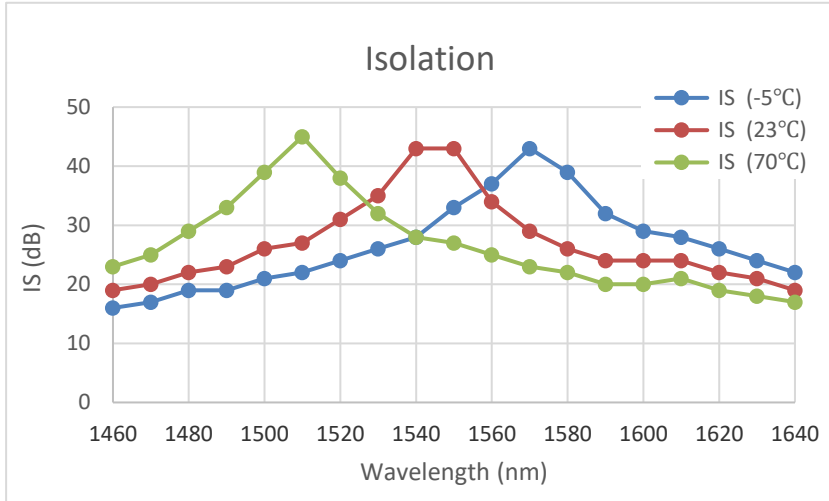

# 1310/1550 nm High Power Optical Circulator

## DATASHEET

### Typical Wavelength Dependence for Dual Stage

